

# Sartorius Miras<sup>®</sup> Multi-Functional Bench & Floor Scales

Exclusively from Intelligent Weighing Technology<sup>™</sup>



# Sartorius Miras®: Quality Meets Affordability

Sartorius Miras® is a unique Multi-functional line of industrial bench and floor scales. Built-in overload protection, portability (with optional castor wheels), and easy to use functionality make this affordable line of scales a winning combination. Weighing capacities range from 13.2 lbs (6 kg) to 660 lbs (300 kg) in three different platform sizes.

Miras® platforms are equipped with painted steel frames and removable stainless steel weighing pans for years of dependable service and easy cleaning. Stainless steel column

(tube) is standard with all models and is easily removable. Indicator can be set on a bench or adapted with our optional wall bracket for easy mounting.

Built-in applications and features include; check-weighing, mass unit conversion, counting and Gross|Net displayed and printed features. The Miras® series of scales are ideal for multiple weighing applications including incoming|outgoing inspection, inventory management, quality control, packaging, formulation and more...

## Features

- Large (1 inch) backlit "Amber" LCD display
- 30,000 digit external displayed resolution
- Fast stabilization time
- Selectable weighing units: kg, lbs, oz & grams
- Checkweighing with numerical input (HI|OK|LO displayed symbols for easy reference)
- Counting with fixed reference samples: 5, 10, 20, 50, 100
- Stainless steel weighing pan
- Painted steel frame
- IP65 protection (weighing platform)
- Optional Battery operation (six "D" size batteries)
- Built-in overload protection (150% of capacity)

RS-232 output for computer or printer connection

Large 1" (25 mm) LCD display with amber backlighting. Easy to read even under poor lighting conditions.



ABS plastic housing resistant to aggressive cleaning agents

Zero

Tare

Gross | Net

Function key  
- Counting  
- Checkweighing  
- Unit conversion

Print | Enter key

Simple "functionality" and "general" weighing Easy set-up and installation allow you to get started quickly and efficiently. Attach the column and plug your scale in and you are ready to weigh – minimal warm-up time is needed. Large "On|Off", "Tare" & "Zero" keys make for convenient and easy use.

#### **Checkweighing**

Selectable numeric lower and upper limits provide easy and convenient set-up. Display shows HI|OK|LO for easy operator reference.

#### **Simple counting function**

Select fixed reference sample (5, 10, 20, 50, 100) from menu. Place exact number of parts to be counted onto the scale and press enter. Then place the remainder of your parts to be counted; the total number of pieces is shown on the display instantly.

#### **Net|Total formulation**

With Miras® indicators, users can deduct and store the weight by pressing the tare button repeatedly, up to the scale's capacity, and can then toggle between gross and net weight. This function is ideal for weighing multiple ingredients for formulation purposes.

#### **Easy-to-use tare function**

with Gross|Net weight display

Place a container on the platform and press the tare key. The tare is automatically stored in memory and the net weight is displayed. The user can easily toggle the display between gross and net weight by pressing the Gross|Net key.



Model Number	Weighing capacity lb   kg	Readability lb g	Column height in mm	Platform dimension in	Platform dimension mm
IW2P1U-6ED-L	13.2   6	0.0005   0.2	19.7   500	15.7 + 11.8	400 + 300
IW2P1U-15ED-L	33   15	0.001   0.5	19.7   500	15.7 + 11.8	400 + 300
IW2P1U-30ED-L	66   30	0.002   1	19.7   500	15.7 + 11.8	400 + 300
IW2P1U-60ED-L	132.2   60	0.005   2	19.7   500	15.7 + 11.8	400 + 300
IW2P1U-60FE-L	132.2   60	0.005   2	29.5   750	19.7 + 15.7	500 + 400
IW2P1U-150FE-L	330   150	0.01   5	29.5   750	19.7 + 15.7	500 + 400
IW2P1U-300GF-L	661   300	0.02   10	29.5   750	25.6 + 19.7	650 + 500

## Specifications

External resolution:	30,000 divisions
Display:	LCD, 6 digits, character height:25mm (1") 7 segments, with amber backlight
AC Line voltage:	120V standard 3-prong cable with internal universal power supply
Battery operation:	Option of using 6 "D" size 1.5V batteries
Temperature range:	14 to 104° F (-10 to 40° C) Up to 85% Relative Humidity
Weighing pan:	Stainless Steel
Weighing system:	Load cell(s) with IP65 rating
Compliance:	UL CSA,CE
Communications port:	RS-232 Interface DB9 pin for PC connection

## Accessories

- YDH01i: Indicator wall-mounting bracket
- YDP06: Printer
- YR001S-SL: Set of 4 castor wheels

Size   Dimension		A	B	C	D	E	F	G
in	mm							
15.7 x 11.8	400 x 300	23.6	27.7	5	13.8	10	15.7	11.8
19.7 x 15.7	500 x 400	27.9	37.6	5.2	17.6	11.7	19.7	15.7
25.6 x 19.7	650 x 500	33.8	37.6	6.1	23.5	15.6	25.5	19.7

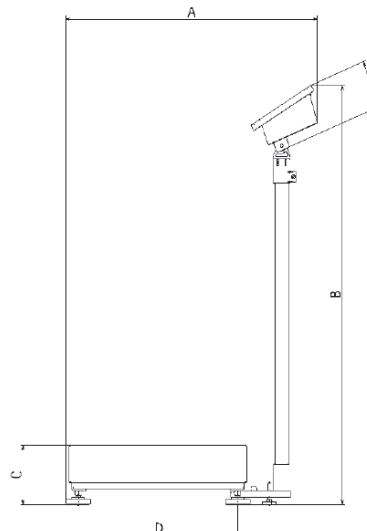
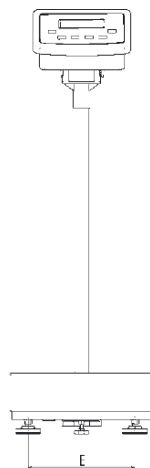
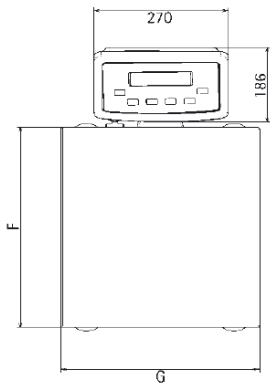

Available Exclusively From  
**Intelligent Weighing Technology, Inc**  
 4040 Adolfo Rd  
 Camarillo, CA 93012

Toll Free: 866-920-3000  
 Phone: 805-642-3034  
 Fax: 805-642-4034  
 Email: [sales@intelligentwt.com](mailto:sales@intelligentwt.com)